

VON DUPRIN

7311 Keypad

Operation Manual

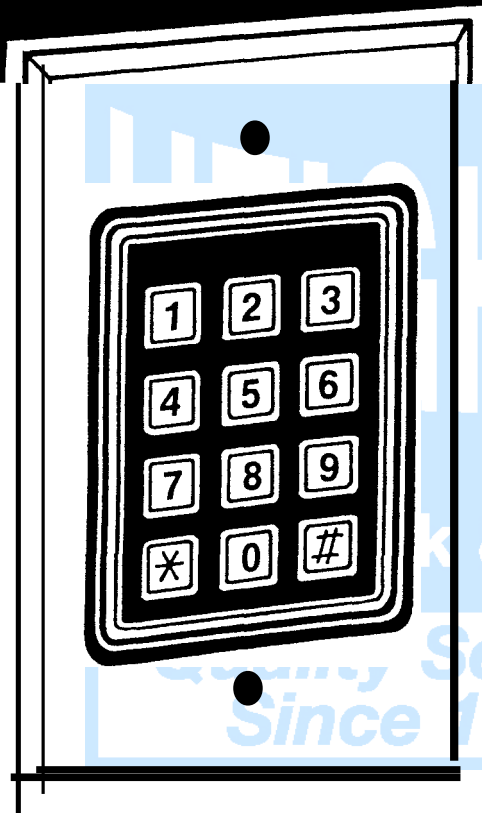

VON DUPRIN

Part of worldwide Ingersoll-Rand

SECTION 1 INTRODUCTION

General Description

The Von Duprin 7311 keypad is a self-contained access control unit which fits in a single-gang electrical box. It requires a power supply and locking device to make a complete system. The keypad uses non-volatile solid state memory so when power fails or is removed, programmed memory is retained. The Von Duprin 7311 keypad holds 100 different codes (user positions 1 through 100). All programming is accomplished through the keypad. The keypad has multiple inputs and outputs preprogrammed for specific functions. Two inputs are available: a request-to-exit switch that operates the unlock relay and a door position switch. One standard SPOT (single-pole, double-throw) output is used for lock control.

The Von Duprin 7311 keypad is available with an optional plug-on 7308 relay board which provides three additional SPOT output relays. These relays can operate an alarm shunt output and signalling features to report a door open, duress code input, or keypad lockout due to incorrect code entries.

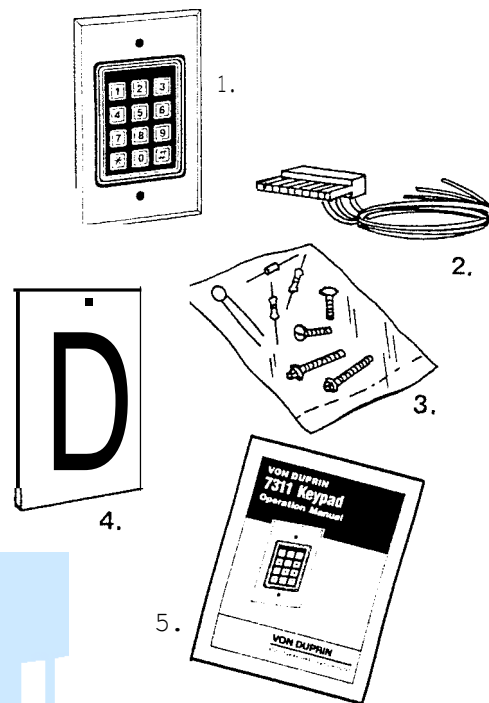

7311 Packing Checklist

- i. 7311 Keypad
2. 3-Wire harness
3. Hardware Pack contains: diode, resistor, MOV, 2-slotted screws, 2-security screws
4. Gasket
5. 7311 Installation and Operation Manual

Specifications

Faceplate-Stainless steel single gang plate.
Circuit board dimensions: 1.7"W x 2.6"H x 1.675"O
Voltage: 12 or 24 volts DC (field selected)
Current: @12VDC 150 milliamperes
 @24VDC 150 milliamperes
Outputs: Lock Relay SPOT 2 ampere @24VDC
 (can operate one EL device)
Temperature Range: -20F (-28C) to 130F (54C)

Latch/Toggle — Any code programmed for latch/toggle changes the state of a relay in a maintained fashion until another code programmed for latch/toggle is entered.

Terminology

Keys — There are 12 keys: 0-9, # and *. The # is used to signify the separation of commands, times, or users when programming. The * is used to signify the end of a code entry.

Codes — Codes are user numbers that are programmed to unlock the door or perform other functions. Codes may consist of 2 to 6 digits, with any combination or repetition allowed. This provides for over one million possible codes.

Default — Default is the initial power up value assigned to a specific function. For example, the unlock relay default time is 5 seconds.

User positions — There are 100 user positions available:

Master code — Always user position 1: Entering code unlocks door, Entering code after 99# accesses programming mode.

Supervisors -Always user positions 2 and 3: Entering code unlocks door, Cannot access programming mode, Clears 30 second lockout alarm (wrong entries) before it times out.

The remaining ninety-seven user positions 4 through 100 are non-programming and may contain one of three types of user codes. They include:

User — Entering code unlocks door, and if equipped with optional 7308 board actuates relay 2.

Duress — Entering code unlocks door, and if equipped with optional 7308 board actuates relay 2 and relay 4.

Lockout — Entering code toggles use of codes in higher user positions ON/OFF.



Features

1. Yellow program LED: Flashes when any key is pressed, and indicates various programming modes.
2. Red/green LED: Shows status of the relay. Red indicates locked, green indicates unlocked.
3. Plastic protector: Wraps over circuit board to prevent wires from shorting against electrical box.
4. J1 jumper: Removing and replacing this jumper when power is applied to the keypad will force keypad into programming mode.
5. 4-Pin LED terminal: For 4-pin connector for red and green LEDs.
6. PA1 terminal pins: For 2-pin LED connector.
7. J2 jumper: 12VDC or 24VDC voltage selector.
8. +, - Input voltage terminals: 12VDC or 24VDC, as selected by J2 jumper.
9. Unlock relay: (NO, C, NC) 2 ampere SPDT contact controls door strike or other equipment. This relay contact switches when a correct code or a request-to-exit input is entered. Actuation time is programmable.
10. Door position switch input: (White wire) Connecting a normally closed switch between the white/orange wire and the white wire allows the keypad to monitor the door position. The door will

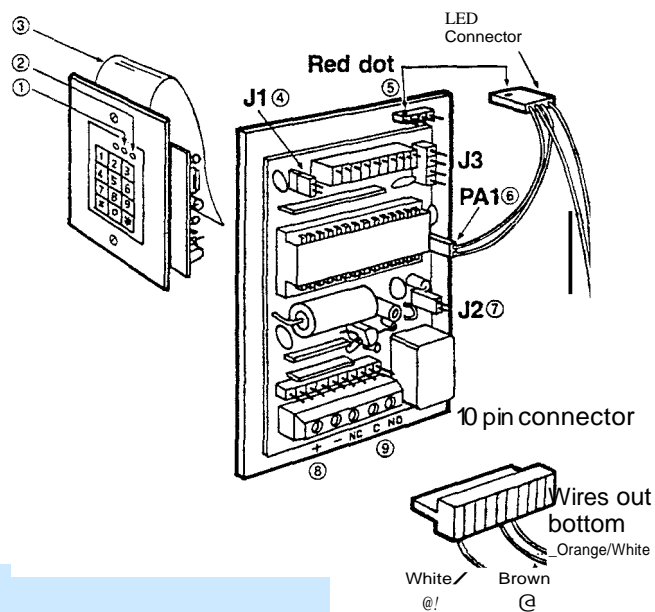

automatically relock as soon as it closes, preventing another person from following through an unlocked door. This automatic relock feature requires the use of a door position switch. An additional output relay may be triggered on alarm when used with the 7308 relay board.

11. Request-To-Exit input: (Brown wire) A momentary closure between the white/orange wire and the brown wire will activate the unlock relay for the same time period as programmed for the master code. NOTE: This will only work if the door position switch is closed.

SECTION 2 INSTALLATION

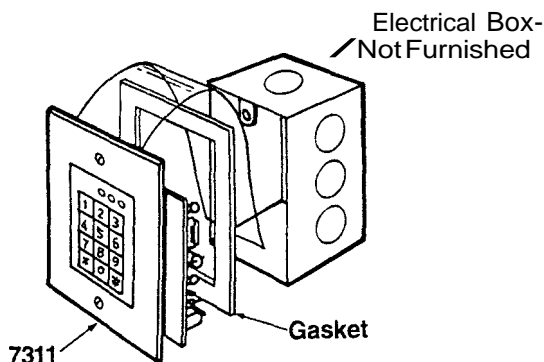

1. Locate keypad at height to suit user. Check handicap requirements in your jurisdiction.
2. Install keypad in a single-gang electrical box (not furnished).

Pull wires to junction box:

3. Pull power supply wires
4. Pull door lock wires
5. Pull door position switch wires, if equipped
6. Pull request-to-exit switch wires, if equipped

Install 7311 keypad:

7. Install gasket between keypad and wall (sticky side toward keypad).
8. Attach keypad to single-gang electrical box (not furnished) with supplied screws.



INITIAL CONFIGURATION AND TEST

Wire LED's:

1. Plug the 4-wire connector onto the 4 pins (not labelled) at the top of the circuit board. Make sure the red dots are in alignment!
2. Wire the two loose red wires to the "+" terminal as shown.

Select proper voltage for operation:

3. The control board is shipped with the voltage selector jumper (J2) installed on one pin for 24 volt operation. Confirm this position.
4. For 12 volt operation, install the jumper (J2) on both pins.

Connect power:

5. The power supply, 12 or 24 volts as set by jumper J2, is connected to "+" and "-" terminals on terminal strip at bottom of circuit board.
6. **TURN ON THE POWER**
The red LED will come on solid indicating the relay is in the locked position.

Test keypad:

7. Enter the factory default code:

1-2 3-4-*

The relay will "click" and the red LED will turn green for 5 seconds (factory default time).

NOTE: If you do not get this response, refer to "troubleshooting" section.

8. **TURN OFF THE POWER**

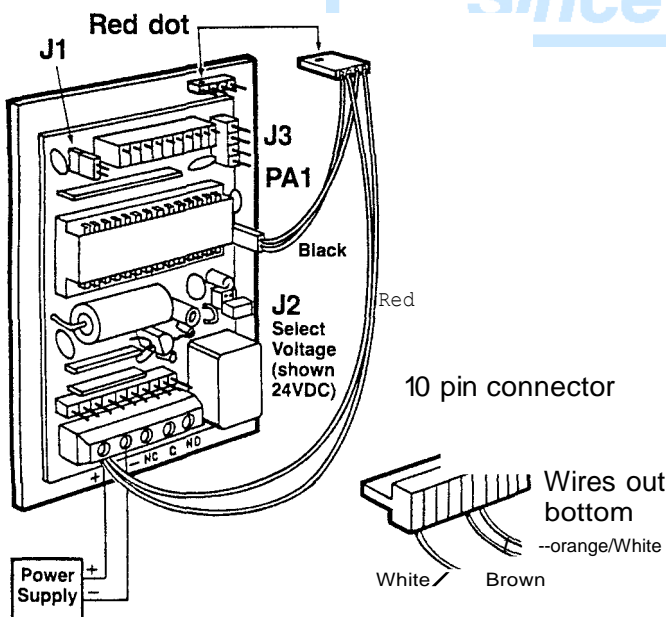

Connect door position switch to the 3-wire harness on the 7311 keypad:

9. If a door position switch is not used, tie the white and white/orange wires together and insulate the connection.
10. The door position switch input requires a closed-when-secure contact between the white/orange wire and the white wire in order to monitor the door position and control the unlock relay. If the door is equipped with such, connect it to the white and white/orange wires.

Connect the request-to-exit switch to the 3-wire harness on the 7311 keypad:

11. If the request-to-exit switch is not used, insulate the brown wire.
12. A momentary closure between the brown and white/orange wires will activate the unlock relay for the same time period as programmed for the master code. If a request-to-exit switch is used, connect the normally open contacts to the brown and white/orange wires. NOTE: This will only work if the door position monitor loop is closed.
13. **TURN ON THE POWER**
14. Test the switch by closing the request-to-exit switch. The unlock relay will click and remain energized as though a valid code had been entered.
15. **TURN OFF THE POWER**

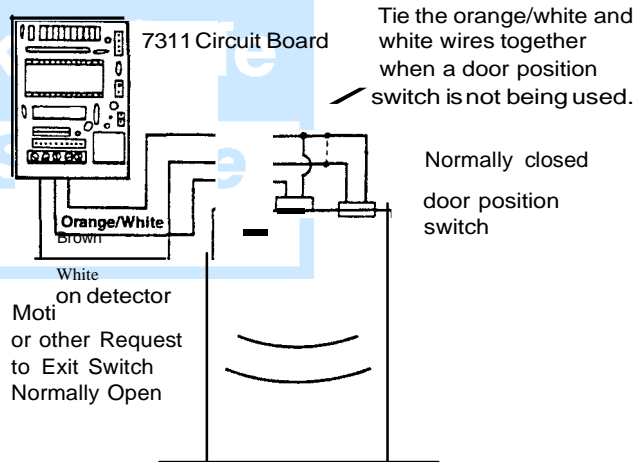

Note: If optional relay board is used, see installation sheet included with 7308 board to attach inputs.

Connect lock:

16. The unlock relay has SPOT contacts to control a fail-safe or fail-secure operation.

17. If the lock uses the same power supply as the keypad, use one of the following wiring diagrams.

18. To use the keypad power supply, install a jumper from the "+" terminal to the common "C" terminal of the unlock relay.

19. Connect one wire of the load to the "-" side of the supply and the second wire to a contact on the unlock relay. Use the NC for fail-safe and the NO for fail-secure.



Test lock:

20. Apply power to lock power supply and, if separate, to keypad supply.
21. Verify that the lock is locked before entering a code.

22. Enter the factory default code [1-2-3-4-*] or another programmed valid code.
23. Lock should release.

Example Application 1

7311 Circuit Board

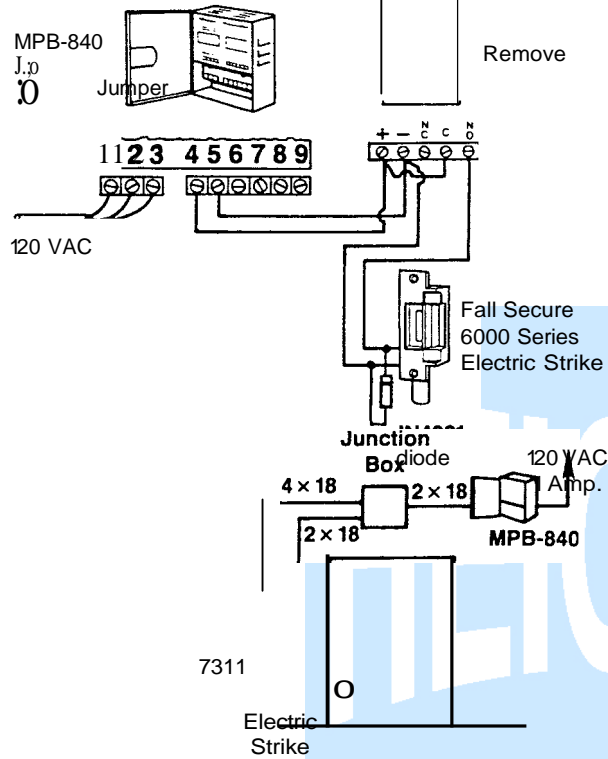

Example Application 2

7311 Circuit Board

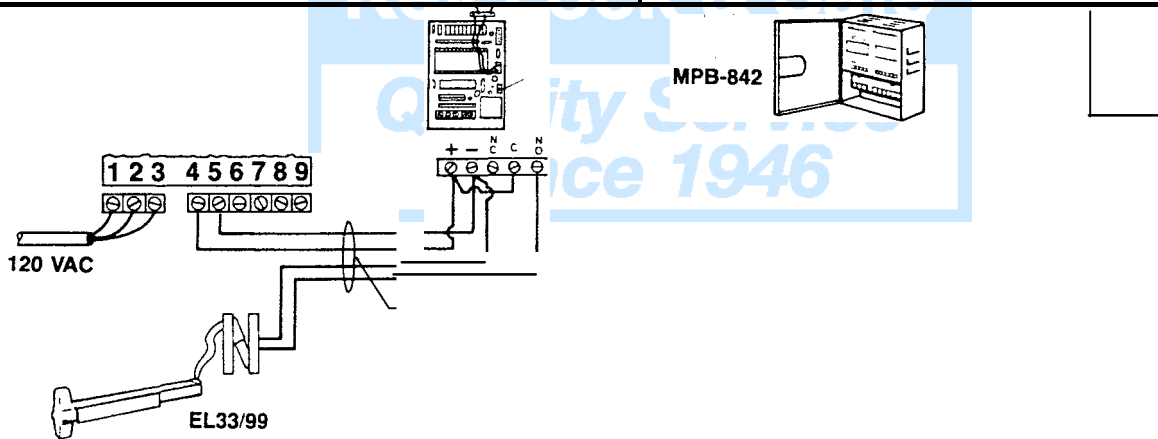
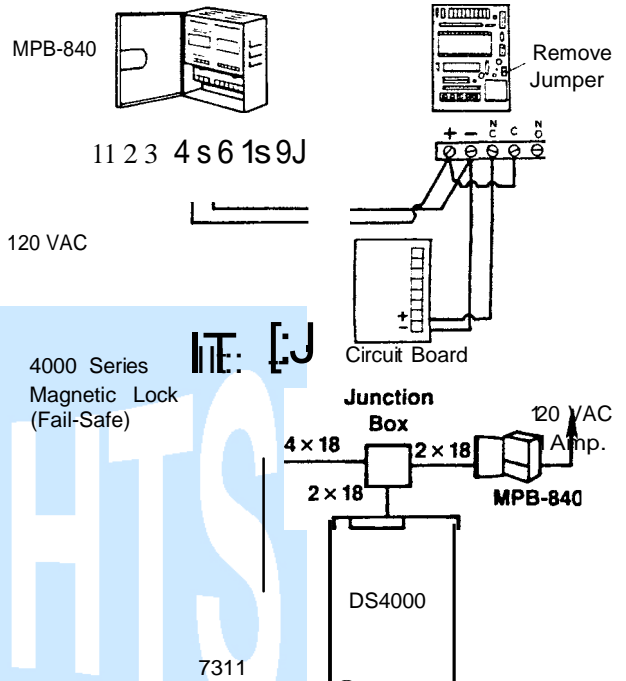

Example Application 3

7311 Circuit Board

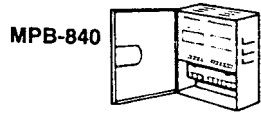

Remove Jumper

12 Gauge Wires

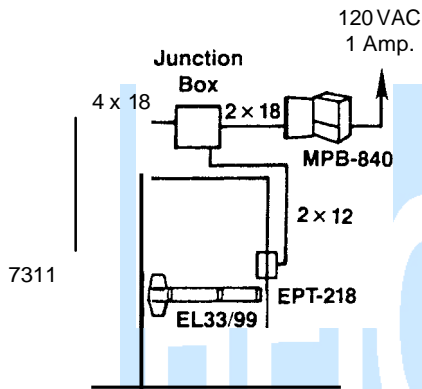

Example Application 4

7311 Circuit Board

Remove Jumper

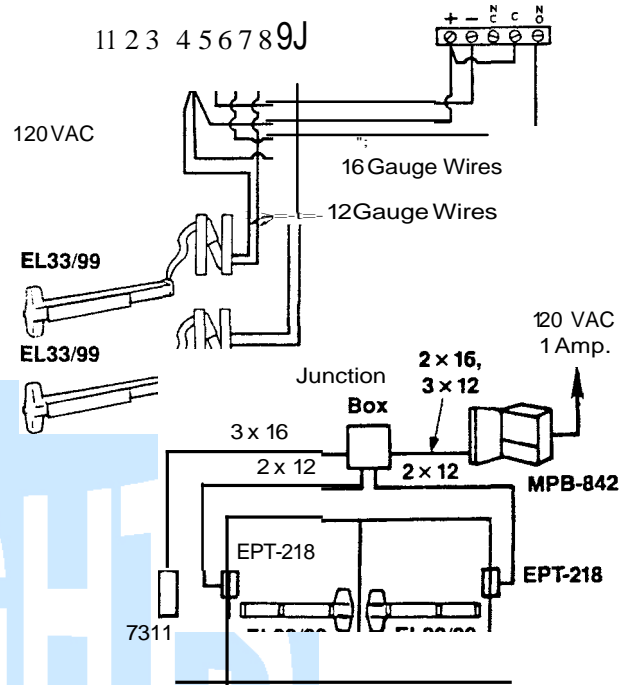

Key Lock & Safe

Quality Service
Since 1946

SECTION 4 PROGRAMMING

The keypad can be programmed prior to installation. Programmed information is stored in nonvolatile memory so it will not be lost when power is removed.

To Enter Programming Mode: Press 9-9-# and the master code *Factory set at 1-2-3-4*, followed by the *-

Note: You must press * after entering any code number. Many commands dealing with user codes require the code to be entered twice during the programming sequence for verification purposes. The keypad will automatically log out of programming mode after 30 seconds without a key entry.

The keypad is now in programming mode, and the yellow light will flash slowly. The unit is preprogrammed with a factory code of 1234. This code is removed when you program a master code (See command 50). If the master code is forgotten, remove and replace jumper J1 when power is applied to force the keypad into programming mode.

To Exit Programming Mode: Press *- The yellow LED will stop flashing.

Note: If a programming error occurs, indicated by a solid yellow LED, simply press *- The yellow LED should start flashing again. Re-enter command.

Command	Function	Code Entry
46	Erase complete memory. Erases the master code. After executing this command, go to command 50 and define a new master code. If keypad logs out of programming mode before you define a master code, briefly remove jumper J1 to access programming.	46#00000#00000#**
50	Change master code. The code in user position 1 actuates the unlock relay and also accesses programming mode. See command 99. Default: factory code = 1234.	50#T#1#Code*Code* T=0 to 90 seconds (O=toggle) Code=2 to 6 digit number
50	Add user. These codes will unlock door. In addition, the codes in user positions 2 and 3 will clear the keypad lockout prior to its timeout.	SO#T#U#Code*Code* T=0 for toggle or 3 for master time U=user position 2 to 100 Code=2 to 6 digit number
50	Delete user, duress user, lockout user. Erases code in user positions 2 to 100.	SO#O#U#** U=user position 2 to 100
52	Add user lockout location. These codes disable users in higher numbered user positions until the user lockout code is entered again (toggle ON/OFF). User lockout codes will not unlock door.	52#0#U#Code*Code* U=user position 2 to 100 Code=2 to 6 digit number
70	Set keypad lockout count. Multiple incorrect code entries will not allow a user to unlock the door for 30 seconds. Indicated by a solid yellow LED. The master and supervisor codes (users 1, 2, and 3) clear the keypad for use. Default =3 wrong entries.	70#0#N#** N=3 to 25 wrong entries
99	Enter programming mode. Default=master code is 1234.	99#Master* Master=master code (see command #SO)



Additional Commands for 7308 Board:

Command	Function	Code Entry
44	Set door-held-open time. Default: After 10 seconds, actuates relay 3. Resets when door is closed or a valid code is entered.	44#T#O#** T = 10 to 900 seconds
45	Set door forced-open time. Default: Actuates relay 3 for 10 seconds, Resets automatically after time expires.	45#T#O#** T = 10 to 900 seconds
51	Add duress user. This code activates the main relay for the master code time to unlock the door and also activates the duress alarm output relay 4 for 10 seconds.	51#O#U#Code*Code* U=user position 2 to 100 Code=2 to 6 digit number

EXAMPLE: Adding User Codes

Code Sequence:

COMMAND # CC#	TIME # T#	USER POSITION # U#	CODE * CODE *	CODE * CODE *
STEP 1: Enter program mode: 99# [master code]* Response: yellow LED slow flash			STEP 4: Enter the USER position: U# (1 to 100) Response: yellow LED slow flash	
STEP 2: Enter command: CC# (Program Command function) Add user CC =50 Add duress user CC =51 Add lockout user CC=52 Response: yellow LED slow flash			STEP 5: Enter the user code: [_ _ _ _ -I* (2 to 6 digits) Response: yellow LED fast flash	
			STEP 6: Verify user code was entered correctly: [_ _ _ _ -I* (same 2 to 6 digit number) Response: yellow LED slow flash	
STEP 3: Enter time: T# (0 to 90 seconds) If T=0, code will toggle the lock (locked to unlocked or vice versa). If set to 3, time equals the master time set in position number 1. Any other number will set a unique time for this user. Response: yellow LED slow flash			STEP 7: To program another command begin at step 2, or	
			STEP 8: To end program mode PRESS the * key again. Response: yellow LED stops flashing	



SECTION 5 TROUBLESHOOTING

Symptom	Cause	Solution	Procedure
No red LED on power up	No voltage at circuit board input terminals.	Verify a minimum of 10.5VDC (12VDC) across "+" and "-" voltage input terminals.	<ul style="list-style-type: none"> • If the minimum voltage is not present, check the output at the power supply for voltage. • If correct voltage is present at power supply, check wiring between power supply and keypad for an open circuit. • If voltage is not present at power supply output, check the fuses. • If fuses are blown, look for a short between the power supply and 7311 keypad. • If fuses are not blown, measure 120VAC input to the power supply. • If no 120VAC, check circuit breaker. • If 120VAC is present, return power supply to supplier for repair.
	Input voltage polarity is reversed at input terminals.	Verify positive lead from DC power supply goes to "+" input and ground to "-" input.	<ul style="list-style-type: none"> • If reversed, then correct. This should not cause damage to the circuit board.
	Voltage jumper (J2) not set properly.	Verify jumper is on both pins to operate on 12VDC voltage.	<ul style="list-style-type: none"> • If not properly set, correct.
Red LED does not change to green when a valid code is entered.	Code was not entered correctly.	Re-enter proper code correctly.	<ul style="list-style-type: none"> • Enter the 2 to 6 digit number (look for yellow flash with each key pressed). • Follow number entered immediately by .
	Code is not valid.	Use master code to enter programming mode and add user code (command 50).	
	Master code was erased when erasing program memory.	Briefly remove jumper J1 to enter programming mode, enter command 50 to redefine master code.	
Red LED turns to green, but lock does not release.	Voltage jumper (J2) not set properly.	Verify jumper is on both pins to operate on 12VDC voltage.	<ul style="list-style-type: none"> • If not properly set, correct.
	Incorrect wiring between keypad and lock.	If lock is fail-secure, remove the wires tied to the "C" and "NO" terminals and tie together. Lock should release. If not, check wiring between keypad and lock for opens. If the lock is fail-safe, remove wire from "NC" output terminal. Lock should release. If lock releases as it should, and keypad is getting correct input voltage, return keypad for repair.	
Master code does not access programming mode.	Did not use current master code.	Press 99#, and enter current code.	
	Master code was reset by erasing memory (command 46).	Remove and replace jumper "J1," use command 50 to redefine master code.	
Request-to-exit switch does not activate unlock relay.	Door position switch is not closed.	Tie the white and orange/white wires securely together.	
Green LED on solid.	Toggle code has been entered.	Enter toggle code again to de-energize relay.	
Yellow LED on solid.	Made a programming error when in programming mode.	Press • to get back to a slow yellow flashing LED.	

	Keypad is in a 30 second entry-error alarm mode. This occurs when a number of wrong user codes are entered.	Enter in a master or supervisory code (user codes 1, 2, or 3).	
--	---	--	--



7311 Keypad Update

0 The pushbutton replaces Jumper J1 in the instructions.

@ LED wires no longer connect to the "+" terminal. All four wires are plugged in, as shown, from the factory.

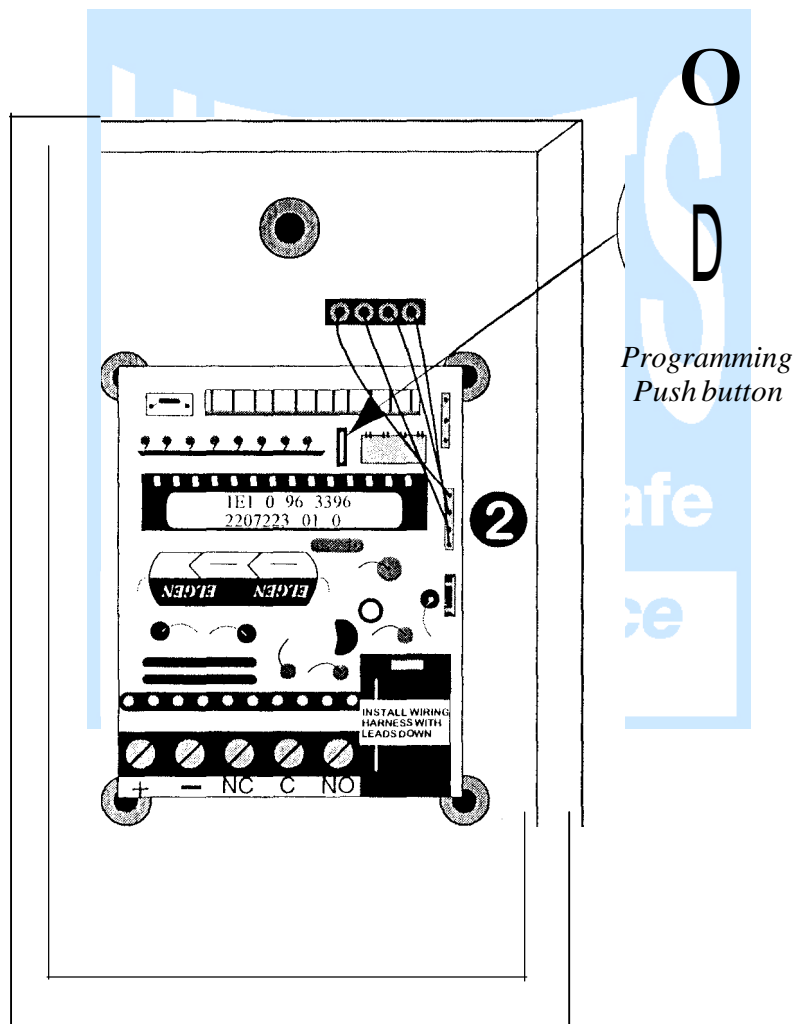

VON DUPRIN

6175010 1.01

INGERSOLL-RAND
ARCHITECTURAL HARDWARE

